



OPTIMIZING STEP-SIZE OF PERTURB & OBSERVE AND INCREMENTAL CONDUCTANCE MPPT TECHNIQUES USING PSO FOR GRID-TIED SYSTEM.

¹ R.NARESH, ² A.SANKEERTHNA, ³ B.TRIVENI, ⁴ M.RAMYA SREE, ⁵ A.PRASAGNA

¹Assistant Professor Department of EEE, Sri Indu College of Engineering & Technology, Hyderabad.

^{2,3,4,5} U.G. Scholar, Department of EEE, Sri Indu College Of Engineering & Technology, Hyderabad.

Abstract: The growing demand for electricity and the depletion of fossil fuel resources have positioned solar photovoltaic (PV) systems as a promising alternative for future energy needs. Solar energy has gained significant importance due to its abundance and sustainability. However, solar panels exhibit nonlinear current–voltage (I – V) characteristics, with a distinct Maximum Power Point (MPP) that varies based on environmental conditions such as temperature and solar irradiation. To ensure maximum energy extraction, PV systems must continuously operate at their MPP despite changing environmental factors. This is achieved through Maximum Power Point Tracking (MPPT) techniques, which enhance the overall efficiency of solar power systems. Various MPPT methods have been developed, including Perturb and Observe (P&O), Incremental Conductance (InC), Constant Current, Constant Voltage, Fuzzy Logic Control, and Neural Network-based approaches. This paper focuses on a comparative analysis of two widely used MPPT techniques: Perturb and Observe (P&O) and Incremental Conductance (InC). The performance of these methods is evaluated through simulation of a PV array integrated with a boost converter using MATLAB/Simulink. The study highlights their effectiveness in tracking the maximum power point under varying operating conditions, contributing to improved energy efficiency in solar PV systems.

Keywords: Photovoltaic (PV) System, Maximum Power Point Tracking (MPPT), Maximum Power Point (MPP), Perturb and observe (P&O), Incremental Conductance method (InC), Boost Converter.

I. INTRODUCTION

Now a days as the world population is increasing rapidly, therefore demand of electrical energy is also increases accordingly and the available energy sources are not sufficient to meet these demand. So renewable energy sources are the best alternatives for that problem. In that Solar energy is best option, because it is abundantly available, it is a clean source of energy, and its conversion to electricity is easy i.e. by using PV Array. The ever-increasing demand for low-cost energy and growing concern about environmental issues has generated enormous interest in the utilization of nonconventional energy sources such as the solar energy. The fact that the output of the solar PV system is dependent upon the solar irradiance and temperature. In order to get maximum power from the solar panels the Maximum Power Point Tracking (MPPT) controllers can play an important role in photovoltaic systems, they have to operate at their maximum power point (MPP) despite the changes in the environment conditions. Maximum Power Point Tracking (MPPT) which significantly increases the efficiency of the solar photovoltaic System. To operate the PV array at its maximum power point, the PV system can implement a maximum-power point tracking (MPPT) controller and therefore MPPT algorithms are necessary because PV arrays have a non linear voltage-current characteristics. These voltage-current characteristics have a unique point, where the power produced is maximum. This point depends on the varying environmental conditions. These conditions change during the day and are also different depending on the seasons. There are different MPPT

control methods used for solar PV systems, Incremental conductance(InC), Perturb and observe(P&O), Constant Current method, Constant Voltage method, Fuzzy Control, and Neural Network Control. Among these entire methods Incremental conductance (InC) and Perturb and observe (P&O) are commonly used because of their simplicity and more popular.

For this reason, this paper presents the details Comparative Analysis of the Perturb-and-Observe and Incremental Conductance MPPT Techniques using Boost Converter and the simulation model of the PV based system with MPPT algorithm will be implemented in the Matlab/Simulink. This comparative analysis is designed to determine which of these two methods are the most suitable for MPPT in order to establish an optimal algorithm.

II. MODELING OF PV CELL

The model of the solar PV cell can be realized by an equivalent circuit that consists of a current source in parallel with a diode as shown in figure. 1 for ideal model R_s , R_p and C components can be neglected.

The diode is the one which determines the current-voltage characteristic of the cell. The output of the current source is directly proportional to the light falling on the cell. The open circuit voltage increases logarithmically according to the Shockley equation which describes the interdependent of current and voltage in a solar cell.

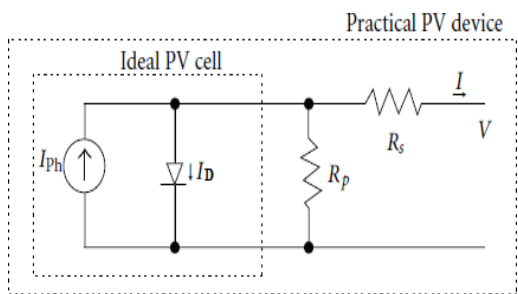

Fig. 1 Equivalent circuit diagram of a solar PV cell

An equation that represents I -V characteristics of a solar array is given by the following mathematical equation as

$$I = I_{ph} - I_s \left(e^{\frac{q(v+IR_s)}{mKT}} - 1 \right) - \left[\frac{V+IR_s}{R_p} \right] \text{-----(1)}$$

Equation (1) is used in computer simulations to obtain the output characteristics of a solar cell. To simulate the selected PV array, a PV mathematical model having N_p cells in parallel and N_s cells in series is used according to the following equation (neglecting shunt resistance):

$$I = N_p I_{ph} - N_p I_s \left(e^{\frac{q(v+IR_s)}{mKT N_s}} - 1 \right) \text{----- (2)}$$

Assuming N_p the above equation can be rewritten as:

$$I = I_{ph} - I_s \left(e^{\frac{q(v+IR_s)}{mKT N_s}} - 1 \right) \text{----- (3)}$$

In particular, the cell reverse saturation current, I_s , varies with temperature according to the following equation as:

$$I_s = I_{s(T_1)} * \left(\frac{T}{T_1} \right)^{3/4} * e^{\frac{-qV}{mKT}} \left(\frac{1}{T} - \frac{1}{T_1} \right) \text{----- (4)}$$

$$I_{s(T_1)} = \frac{I_{sc(T_1)}}{(e^{qV_{oc}} / (T_1) / mKT_1 - 1)} \text{----- (5)}$$

The photo current I_{ph} , depends on the solar radiation (S) and the temperature (T) according to the following equation as:

$$I_{ph} = I_{ph(T_1)} (1 + K_0 (T - T_1)) \text{----- (6)}$$

$$I_{ph(T_1)} = S * I_{sc(T_1, norm)} / S_{norm} \text{----- (7)}$$

Where $K_0 = (I_{s(T_2)} - I_{s(T_1)}) / (T_2 - T_1) \text{----- (8)}$

The series resistance of the cell is given as

$$R_s = \frac{dV}{dI_{voc}} - \left(\frac{1}{X_v} \right) \text{----- (9)}$$

Where $X_v = I_{0(T_1)} * q / mKT_1 * (e^{qV_{oc}} / (T_1) / mKT_1) \text{----- (10)}$

I_{sc} - light-generated current,
 K - Boltzman constant ($1.38 * 10^{-23}$ J/k),
 T_k - temperature (K), n_s number of PV cells connected in series,
 N_p - number of PV cells connected in parallel,
 I_0 - reverse saturation current which depends on the ambient temperature
 m - diode factor (usually between 1 to 2);
 n_s : number of PV cell in series
 n_p : number of PV cell in parallel
 The specifications of the PV array shown in table 1

Table 1 Specifications of the PV panel

At temperature=25°C		
Open circuit voltage	V_{oc}	21.8 V
Short circuit current	I_{sc}	4.51 A
Voltage at max power	V_m	17.2 V
Current at max power	I_m	3.94 A
Max power	P_m	70.0 W

The PV module can be operated in any point on the I-V curve between the I_{sc} and the V_{oc} . However, the power from the PV module is different in every operating point as shown in the P-V curve in figure 2.

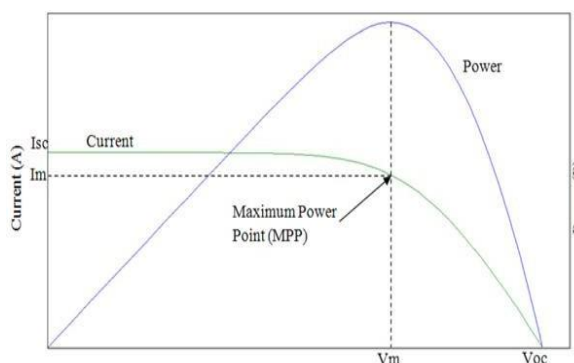

Fig. 2. PV array I –V and P–V characteristics.

Therefore, a control algorithm is needed in order to ensure that the PV system always operates at the MPP.

Figure 2. is obtained when the temperature and solar irradiation are constant at the standard testing conditions (STC) which are defined as cell temperature = 25° C, incident solar irradiance = 1000W/m², and air mass (AM) = 1.5.

III. PV SYSTEM WITH MPPT CONTROL



The PV power, P, is then calculated as follows

$$P = N_p I_{ph} V - N_p I_s V \left(e^{\frac{q(V+I R_s)}{m k T N_s}} - 1 \right) = VI \dots\dots\dots (11)$$

where

V - output voltage of PV module,

I - output current of PV module,

R_s - series resistance of cell (Ω)

R_{sh} - shunt resistance of cell (Ω)

q - electronic charge (1.602 *10⁻¹⁹ C),

The objective of MPPT algorithm is to adjust the current (I_{mpp}) and voltage (V_{mpp}) of the PV array at which maximum output power (P_{mpp}) is obtained under a specific irradiation and temperature. As mentioned earlier Incremental conductance (InC) and Perturb and observe (P&O) are the most popular techniques for tracking of maximum power. Maximum power point tracking, frequently referred to as MPPT, Tracking the maximum power point (MPP) of a photovoltaic array is an essential



stage of a PV system the efficiency solar panel is improved by Maximum Power Point Tracking (MPPT) when they set to operate at point of maximum power. The operation of MPPT can only be achieved when a tune able matching network is used as interface for load and the PV array. The main constituent components of a PV system are power stage and controller as shown in figure.3. The power stage is optimized using switch mode DC-DC converters (boost, buck-boost), employing pulse width control. The control parameter which is used for synchronizing the network for maximum extraction of power is duty ratio δ . The block diagram of PV system with MPPT control using boost power converter is shown in figure 3.

Although this method can result in oscillation of power

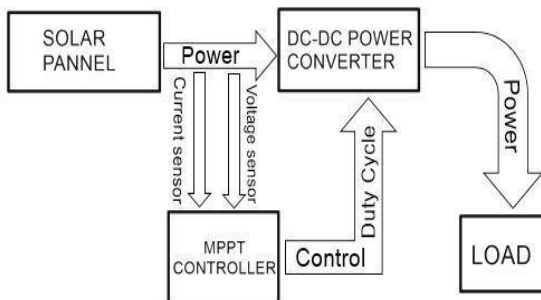

Fig. 3 Block Diagram of PV System with MPPT Control

There are different MPPT techniques such Incremental conductance (InC), Perturb and observe (P&O), Constant Current method, Constant Voltage method, Fuzzy Control, and Neural Network Control. The large number of methods proposed can make it difficult to determine the best technique to adopt when implementing a PV system. Among all those methods the Incremental conductance (InC) and Perturb and observe (P&O) are commonly used because of their simplicity and more popular. They differ in many aspects such as complexity, accuracy, sensors required, cost or efficiency, and speed. Based on the control variable it uses, each method can be categorized.

IV. MPPT CONTROL ALGORITHM

A. PERTURBATION AND OBSERVATION (P&O)

The P&O algorithms are widely used in control of MPPT because of their simple structure and reduced number of necessary measured parameters. The flowchart implementation of P&O method is given in figure 4. As the name implies, the concept behind of this method is based on observation of PV array output power and its perturbation by changing the current or the voltage of PV array operation. The algorithm increments or decrements continuously the reference voltage or current based on the previous value of power until reaches the MPP. When $dP/dV > 0$ and the operating voltage of PV array is perturbed in a specific direction, it known that perturbation moves the operating point of PV array to the MPP. P&O method will then continue to perturb the PV voltage in the same direction. When $dP/dV < 0$, the perturbation moves the operating point of PV array away from the MPP and the P&O method reverses the direction of the perturbation.



output. It is referred to as a hill climbing method. Because, it depends on the rise of power against voltage below MPP and above MPP. Figure 5 shows typical P-V curve at 1000 W/m². On the LHS of the MPP there is linear increase in power with respect to voltage ($dP/dV > 0$). But on RHS of the MPP there is increase voltage with decrease in power ($dP/dV < 0$). So, this P&O algorithm will try to maintain the maximum power point by perturbing voltage with respective power. At MPP change in power with respect to change in voltage is zero ($dP/dV = 0$). Table 2 shows the direction of perturbation of voltage with respect to power.

Table I shows that with same sign of ΔV and ΔP results in direction of step size is positive i.e. + C. and if either sign of ΔV and ΔP results in direction of step size is negative i.e. - C. From flowchart shown in Figure 4, dV and dP is calculated based on the difference between present values of voltage, power and previous samples of voltage and power. Based on the sign of dV , dP the perturbation is approached. Table 2 Shows the sign of perturbation size (C) changing with respect to the sign of dV and dP . For the same sign of dV and dP the perturbation of step size is positive, alternate sign results in negative step size perturbation. This algorithm has the drawback that after reaching the maximum power point its starts deviating on the maximum power point continuously all the time results in the substantial amount of power loss at maximum power point. Although this algorithm is quite simple to implement and it requires only one voltage sensor so, the cost of implementation of this algorithm is low.

Figure. 4 Flowchart of P&O MPPT Algorithm

1. Approaches for Implementation of Perturb and Observe Algorithm

There are two common approaches for implementing the P&O algorithm.
 Reference voltage perturbation

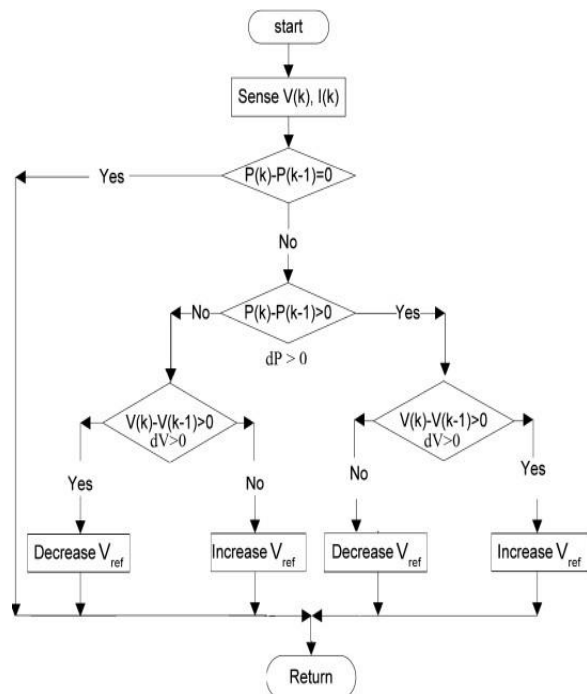



Direct duty ratio perturbation

Table 2 the sign of perturbation size (C)

Sign of ΔV	Sign of ΔP	Direction of next step
+	+	+C
-	-	+C
-	+	-C
+	-	-C

In Reference voltage perturbation, the PV array output voltage reference is used as the control parameter in conjunction with a controller (usually a PI controller) to adjust the duty ratio of the MPPT power converter. The PI controller gains are tuned while operating the system at a constant voltage equal to the standard test condition (STC) value of the MPP voltage. These gains are kept constant while the reference voltage is controlled by the MPPT algorithm. In direct duty ratio perturbation, the duty ratio of the MPPT converter is used directly as the control

parameter. the duty ratio is perturbed directly eliminating the need for a PI controller which in turn reduces the complexity and enhances the stability of the system. This method also offers better energy utilization and better

stability characteristics at a slower transient response and worse performance at rapidly changing irradiance. In this

paper P&O algorithm is implemented with Reference voltage perturbation.

B. INCREMENTAL CONDUCTANCE METHOD

The incremental conductance (InC) algorithm which is shown in figure 5, seeks to overcome the limitations of the perturbation and observation algorithm by using the incremental conductance of the photovoltaic. Incremental conductance method generally uses voltage and current sensors to detect the output voltage and current of the PV array hence the complexity of the algorithm increases. The slope of the PV curve is zero at Maximum Power Point. Incremental conductance method uses two sensors, that is voltage and current sensors to sense the output voltage and current of the PV array. Algorithm works by comparing the ratio of derivative of conductance with the instantaneous conductance. When this instantaneous conductance equals the conductance of the solar then MPP is reached. In general, the IC tracking approaches use a fixed iteration step size, which is determined by the accuracy and tracking speed requirement. The step size may be increased to improve tracking speed, however, accuracy is decreased. Likewise, reducing the step size improves the accuracy, but sacrifices the speed of convergence of the algorithm. The main advantage of this method is it can rapidly track the change in irradiance conditions and respond quickly with a very high accuracy and hence efficiency of the system is better and give better results. However the complexity and the cost of implementation increase. Incremental

between the power efficiency and reliability of tracking MPP. Since the P&O method will move away from the power operating point under rapidly changing light condition and not be able to go back the maximum operating point quickly, this will lead to the inefficient use of the PV array and hence this affects the whole system performance of tracking MPP. Other advantage of using this method is it does not depends on the device physics. The output voltage and current from the source are monitored upon which the MPPT controller relies to calculate the conductance and incremental conductance and to make its decision to increase or decrease duty ratio output. Mathematics of the Incremental Conductance method is discussed below. The output power from the source can be expressed as

$$P = V * I \text{ ----- (12)}$$

The fact that $P = V * I$ and the chain rule for the derivative of product yields

$$\frac{1}{V} \left(\frac{dP}{dV} \right) = \frac{1}{V} \left(\frac{d(V*I)}{dV} \right) = I + \frac{dI}{dV} \text{ ----- (13)}$$

$$V \frac{dV}{dV} \quad V \frac{dV}{dV} \quad V \frac{dV}{dV}$$

Let us define the source conductance G as $G = \frac{I}{V}$ --(14)

And the source incremental conductance as

$$\Delta G = \frac{dI}{dV} \text{ ----- (15)}$$

Conductance method of tracking maximum power point which does not depends on PV module. The advantage of using this method to track MPP is that it is more efficient than the P&O method in a way that it is able to correctly locate the operating point of the PV array. There is a tradeoff



It is observe that the operating voltage below at the maximum power point if the conductance is larger than the incremental conductance and vice versa. The voltage operating point at which the conductance is equal to the incremental conductance. These equations 16, 17, 18 and are graphically shown in fig. 4.

$$\frac{dP}{dV} < 0, \text{ if } G < \Delta G \text{----- (16)}$$

$$\frac{dP}{dV} = 0, \text{ if } G = \Delta G \text{ ----- (17)}$$

$$\frac{dP}{dV} > 0, \text{ if } G > \Delta G \text{ -----(18)}$$

Figure. 5 The P-V curve

The program flow chart for this algorithm is shown in figure 6, the operating output current ($I_{in}(k)$) and voltage ($V_{in}(k)$) are measured from the solar panel. The incremental changes dV and dI are approximated by comparing the most recent measure values for ($I_{in}(k)$) and ($V_{in}(k)$) with those measured in the previous cycle ($I_{in}(k-1)$) and ($V_{in}(k-1)$). Then G and ΔG are computed as per the equations (14) and (15). From equation (17), if $\frac{dP}{dV} = 0$ (i.e.

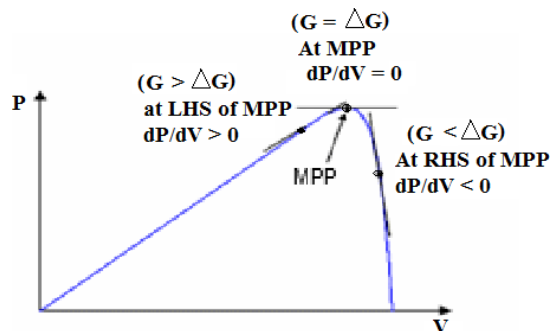



$G = \Delta G$) is true, then the system operates at the MPP and no change in operating voltage is necessary, thus the adjustment step is bypassed i.e. no adjustment for the duty ratio and the current cycle ends. If equation (17) is false, equation (16) and (18) are used to determine whether the system is operating at a voltage greater or less than the MPP voltage and hence to increase or decrease the duty ratio by a step-size of some value accordingly. If the system is operating at the MPP during the previous cycle, the incremental change of the operating voltage is zero ($dV = 0$). This would lead a division by zero i.e. $\Delta G =$

$dI \div dV = dI \div 0$, which is impossible for calculation. To avoid this, the condition ($dV = 0$) is checked first and if true leads to another branch in the algorithm with further tests on possible changes of the panel's operating conditions. Since the voltage $dV = 0$, that means the voltage has not changed; now the only useful information about possible changes are found from the current measurement. If dI is equal to zero, the operating conditions have not changed and therefore the adjustment of the system voltage is bypassed. If $dI > 0$, the duty ratio is increased by step size and is $dI < 0$, the duty ratio is decreased by step size. The program then returns and starts tracking again until the MPP is reached. The maximum duty cycle ratio is set at 90% and the minimum is at 10% and hence contributes to the efficient power transfer of the converter.

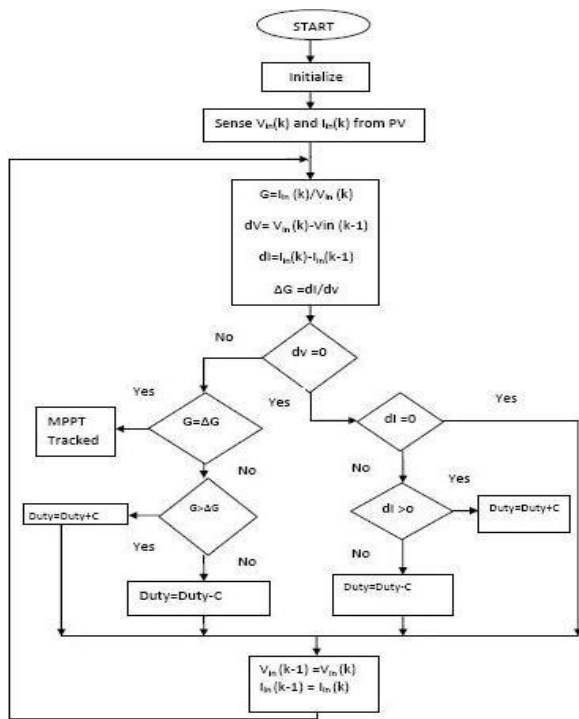

Figure. 6 Flowchart of the IC method.

The drawback of above techniques are mainly two, the first and main one is that they can easily lose track of the MPP if the solar isolation level changes rapidly. The other one is the oscillations of the voltage and current around the MPP in the steady state. This is due to the fact that the control is discrete and the voltage and current are not constantly at the MPP but oscillating around it.

V. BOOST CONVERTER

The boost converter is nothing but a DC/DC converter, which has boosting the voltage to maintain the maximum output power constant for all the conditions of temperature and solar irradiance variations. The MPPT uses the converter to regulating the input voltage at the PV MPP and providing load-matching for the maximum power transfer. The regulation is normally achieved by PWM at a fixed frequency and the switching device is generally BJT, MOSFET or IGBT. There are several different types of dc-dc converters, buck, boost, buck-boost topologies, have been developed and reported in the literature to meet variety of application specific demands.

The topology used for DC to DC converter is boost converter. The boost converter is shown in figure. 7 when the switch S is on, the current builds up in the inductor L due to the positive inductor voltage is equal to the input voltage.

When S is off, the voltage across inductance L reverses and adds to the input voltage, thus makes the output voltage greater than the input voltage. For steady state operation, the average voltage across the inductor over a full period is zero. By designing this circuit we can also investigate performance of converters which have input from solar energy. The boost converters will present low ripple on the PV module side, so here in this experimental work, boost converter is used to verify the output power results.

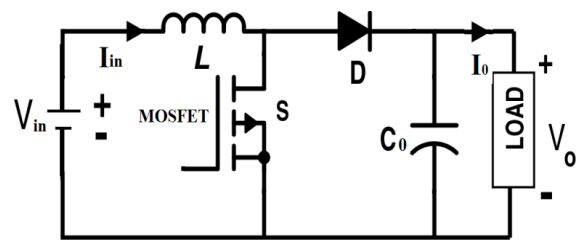

Fig. 7 circuit diagram of boost converter

VI. SIMULATION AND RESULTS

A. SIMULINK MODEL OF PV ARRAY

The complete Simulink model of PV module is shown in Figure 7.

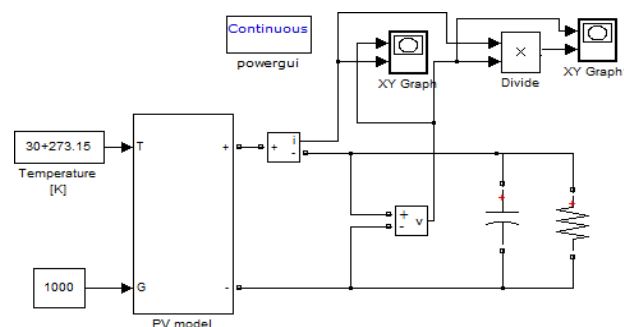

Fig.7.Simulation Model of PV Model

This simulation study is done for the standard test condition (STC) i.e. temperature is 25°C and the Irradiation is 1000 W/m² with the simulation model.

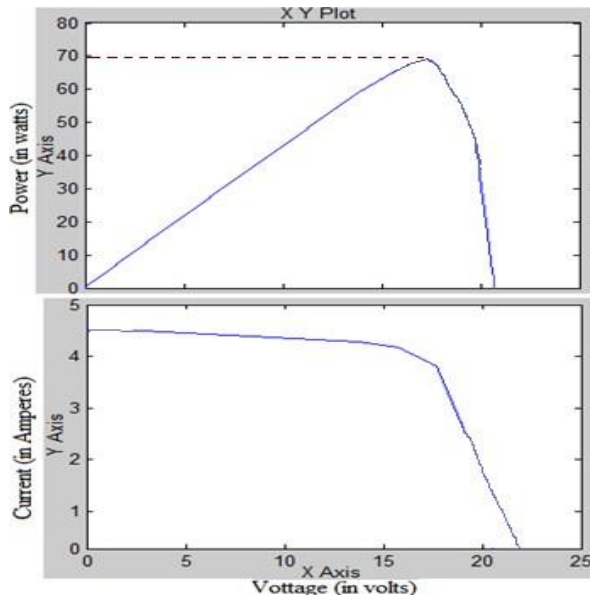
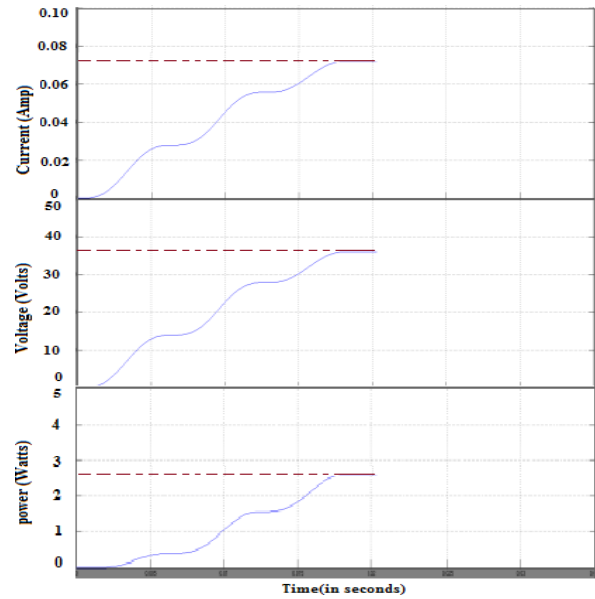

Fig 8. Simulated I-V & P-V Characteristics



0.0175 seconds.

The 70W PV module is simulated in MATLAB and the simulated I-V and P-V characteristics are shown in Figure 8. The open circuit voltage $V_{oc} = 21.8$ V, the short circuit current $I_{sc} = 4.51$ A are obtained for the corresponding maximum output power of 70W.

B. SIMULINK MODEL OF PERTURB-AND-OBSERVE ALGORITHM

The Simulink model of PV array with P&O MPPT algorithm with boost converter is shown in figure 8 and corresponding output waveforms are shown in figure 9.

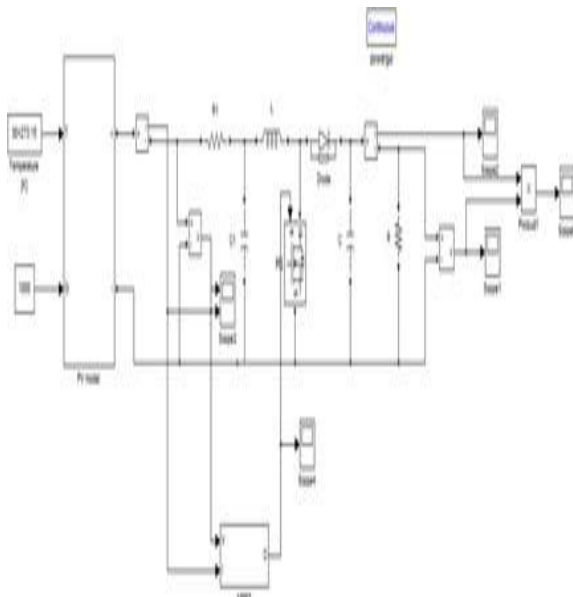

Fig. 8 Simulink Model of P&O MPPT with Boost converter

The simulation results of P&O MPPT algorithm are illustrated in figure 9. The results show that the current output of 0.072 amperes and the voltage output of 36.1 volts and an output power of 2.62 watts for a time period of



Fig. 9 Simulation results of P&O MPPT algorithm of
 (a) Current output (b) Voltage output (c) Power output

C. SIMULINK MODEL OF INCREMENTAL CONDUCTANCE ALGORITHM

The Simulink model of PV array and InC MPPT algorithm with dc-dc boost converter is shown in figure 10, under the same conditions as the P &O algorithm is simulated and corresponding output waveforms are shown in figure 11.

Fig. 10. Simulink Model of InC MPPT with Boost converter

The simulation results of InC MPPT algorithm are illustrated in figure 11. The results show that the output current varies from 0.092A to 0.086A and the output voltage varies from 47.2 V to 43.1 V and an output power varies from 4.72 W to 3.69 W for a time period of 0.1 seconds.

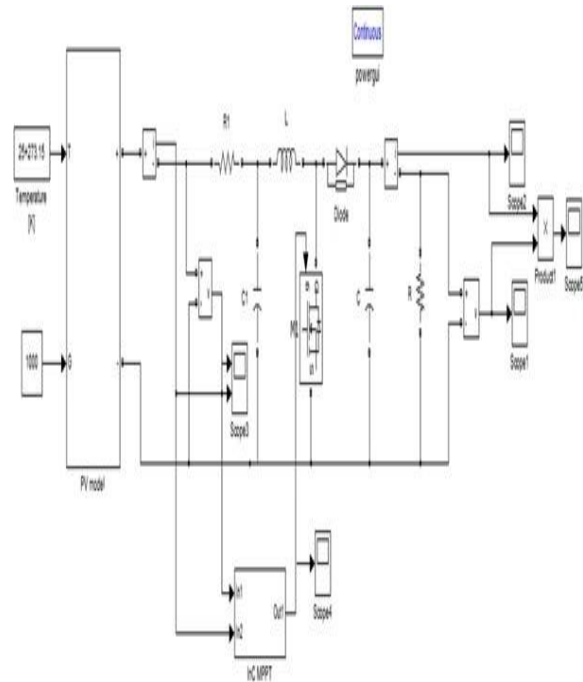

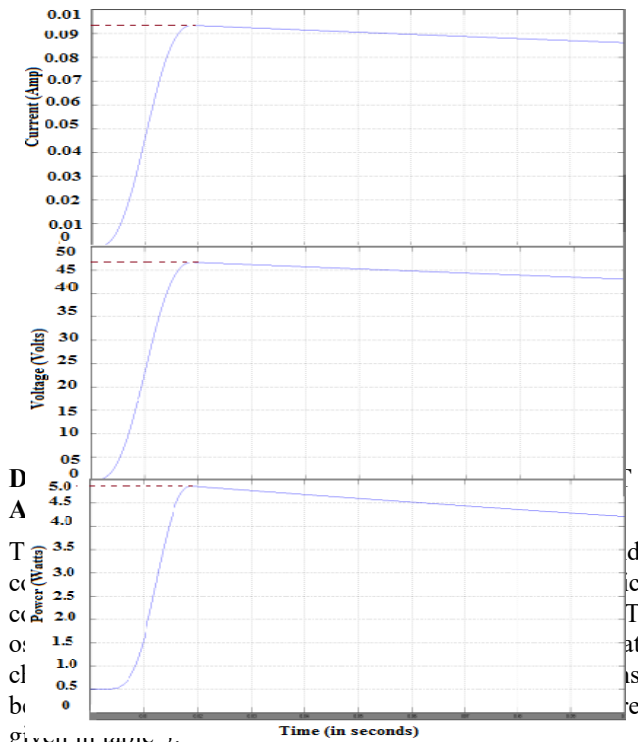

Table 3 Comparison of P&O and InC MPPT algorithms

MPP T	Output Current	Output Voltage	Output Power	Time Response	Accuracy
P&O	0.073A	36	2.6 V	00.0175 sec	Less
InC	0.087-0.093A	43 – 47 V	3.7 – 4.7 V	0.1 sec	Accurate

VI. CONCLUSIONS

In this paper a mathematical model of a 70W photovoltaic panel has been developed using MATLAB Simulink. This model is used for the maximum power point tracking algorithms. The P&O and Incremental conductance MPPT algorithms are discussed and their simulation results are presented. It is proved that Incremental conductance method has better performance than P&O algorithm. These algorithms improve the dynamics and steady state performance of the photovoltaic system as well as it improves the efficiency of the dc-dc converter system.

REFERENCES

- [1] K. H. Hussein, I. Muta, T. Hoshino, and M. Osakada, “Maximum photovoltaic power tracking: an algorithm for rapidly changing atmospheric conditions,” in IEEE Proc.Generation, Transmission and Distribution, 1996, pp. 1752–1757.
- [2] D.Kerekes, T., Teodorescu, R. and Blaabjerg, F. (2006) Improved MPPT Method for Rapidly Changing Environmental Conditions. 2006 IEEE International Symposium on Industrial Electronics, 2, 1420-1425.
- [3] Yu, Y. S. Jung, J. Y. Choi, and G. S. Kim, “A novel two-mode MPPT control algorithm based on comparative study of existing algorithms,” Solar Energy, vol. 76, pp. 455–463, 2004.
- [4] P. Hohm, M. E. Ropp, “Comparative Study of Maximum Power Point Tracking Algorithms Using an Experimental, Programmable, Maximum Power Point Tracking Test Bed”, 0-7803-5772-8/00,IEEE, 2000, 1699-1702.
- [5] Liang-Rui Chen, Chih-Hui Tsai, Yuan-Li Lin, And Yen-Shin Lai, “A Biological Swarm Chasing Algorithm For Tracking the PV Maximum Power Point.”, IEEE Transactions On Energy Conversion, Vol. 25, No. 2, June 2010.
- [6] L.Piegari , R.Rizzo “ Adaptive perturb and observe algorithm for photovoltaic maximum power point tracking”.Renewable power generation, IET, Vol.4, pp. 317-328, July 2010.
- [7] Elgendy, M.A., Zahawi, B. and Atkinson, D.J. (2012) Assessment of Perturb and Observe MPPT Algorithm Implementation Techniques for PV Pumping Applications. IEEE Transactions on Sustainable Energy, 3, 21-33.
- [8] Femia, N., Petrone, G., Spagnuolo, G. and Vitelli, M. (2005) Optimization of Perturb and Observe Maximum Power Point Tracking Method. IEEE Transactions on Power Electronics, 20, 963-973.
- [9] Hiren Patel and Vivek Agarwal, “Maximum Power Point Tracking Scheme for PV Systems Operating Under Partially Conditions”, IEEE Transactions On Industrial Electronics, Vol. 55, No. 4, pp. 963-973, April 2008.
- [10] M. A. Elgendy, B. Zahawi and D. J. Atkinson, “Evaluation Of Perturb And Observe Mppt Algorithm Implementation Techniques”, IEEE conf. on Renewable energy conversion, May 2009, pp. 1-6.
- [11] koutroulis and Frede Blaabjerg (2015) “Overview of Maximum Power Point Tracking Techniquesfor Photovoltaic energy production systems”, Electric Power Components and Systems, 43(12), pp.1329-1351.
- [12] Burri Ankaiah & Jalakanuru Nageswararao, “ MPPT Algorithm for Solar Photovoltaic Cell by Incremental Conductance Method” International Journal of Innovations in Engineering and Technology (JIET)
- [13] faranda, Sonia Leva, “ Energy comparison of MPPT techniques for PV Systems”, Department of Energy Politecnico di Milano Piazza Leonardo da Vinci, 32 – 20133 Milano ITALY
- [14] Johan H. R. Enslin, Senior Member, IEEE, Mario S. Wolf, Dani’el B. Snyman, and Wernher Swiegers, “ Integrated Photovoltaic Maximum Power Point Tracking Converter”, IEEE Transactions On Industrial Electronics, Vol. 44, No. 6, December 1997
- [15] Hairul Nissah Zainudin, Saad Mekhilef, „Comparison Study of Maximum Power Point Tracker Techniques for PV Systems,” Proc. 14th International Middle East Power Systems Conference (MEPCON’10), Cairo University, Egypt, 2010, 750-755.
- [16] Z. Salameh and D. Taylor, “Step-up maximum power point tracker for photovoltaic arrays,” Solar Energy, vol. 44, pp. 57–61, 1990.



- [17] ESRAM, T. and CHAPMAN, P.L. (2007) Comparison of Photovoltaic Array Maximum Power Point Tracking Techniques. IEEE Transactions on Energy Conversion, 22, 439-449
- [18] P. Hohm, M. E. Ropp "Comparative Study Of Maximum Power Point Tracking Algorithms Using an Experimental, Programmable, Maximum Power Point Tracking Test Bed" 0-7803-5772-8/00/2000 IEEE.
- [19] D. Hohm and M. Ropp, "Comparative study of MPPT algorithms using an experimental, programmable, MPPT test bed," in Proc. 28th IEEE conf. Rec. Photovolt. Spec. Conf., 2000, pp. 1699-1702.
- [20] T. ESRAM and P. CHAPMAN, "Comparison of photovoltaic array maximum power point tracking techniques," IEEE Trans. Energy Convers., vol. 22, no. 2, pp. 439-449, Jun. 2007.
- [21] FARANDA, R. and LEVA, S., "Energy Comparison of MPPT techniques for PV Systems," WSES Transaction on Power Systems, vol. 3, pp. 446-455, 2008.
- [22] SELVAN, S.D, Modeling and Simulation of Incremental Conductance MPPT Algorithm for Photovoltaic Applications, International Journal of Engineering Research & Technology (IJERT), Vol. 2 Issue 7, July, 2013.
- [23] RIVERA, O. and E. I., "Maximum Power Point Tracking using the Optimal Duty Ratio for DC-DC Converters and Load Matching in Photovoltaic Applications," IEEE, pp. 987-991, 2008.
- [24] DORAGACHARLA, V. R. (2026). Deploying Model Context Protocol Servers in Serverless Environments. Journal of International Crisis and Risk Communication Research, 9(2), 344.
- [25] JAY BHARAT MEHTA. (2025). AUTONOMOUS PATCH VALIDATION FOR ZERO-DAY EXPLOITS IN ENTERPRISE CLOUDS. International Journal of Applied Mathematics, 38(4s), 1270-1285. <https://doi.org/10.12732/ijam.v38i4s.685>
- [26] REDDY, S. K. R. (2025). Tailoring Loyalty Rewards Systems across Industries: Cloud vs On-Prem Solutions. International Journal of All Research Education and Scientific Methods (IJARESM).
- [27] POOJARI, R. (2026). Privacy-Preserving Generative AI in Healthcare Systems Using Federated Learning Approaches. International Journal of Data Science and IoT Management System, 5(1), 78-88.